

# Road Safety Products

# Anti-Gawk

**BOYLAN**  
GROUP



## Stylish, Slimline Anti-Gawk Screening

### Features & Benefits

- **Strong**- Thermoplastic sandwich panel with fibre-glass reinforcement
- **Easy to Assemble**- Boylan "Easy Mount" brackets
- **Durable**- Weather resistant
- **All Weather**- Excellent UV resistance
- **Resistant**- Highly resistant to salt water; chemicals
- **Long Life** - does not decompose.
- **Compression Strength** - compression strength of area 50 x 50mm is 2.3MPa
- **Design Excellence** - no horizontal frames.
- **Wind Rated** - AS/NZS 1170.2.2002, Regions (A1-7), B, Terrain Category 2, Temporary Structures (V25).

### Head Office

Unit 8, 42 Peter Brock Drive,  
Eastern Creek, NSW, 2766

E [info@boylan.net.au](mailto:info@boylan.net.au) | [boylan.net.au](http://boylan.net.au)

Call us 1300 500 055



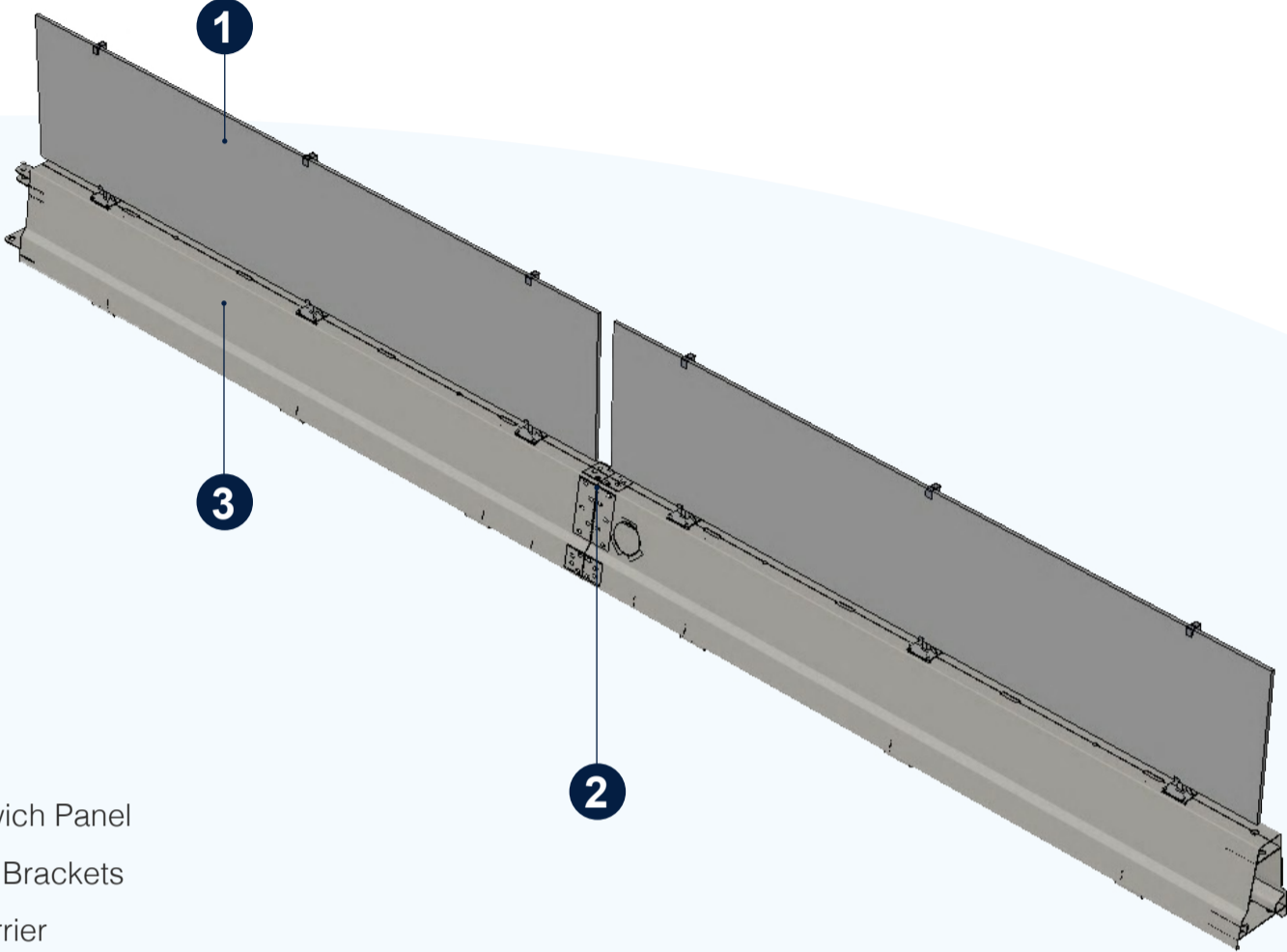

### Specifications

- 1 Thermoplastic Sandwich Panel
- 2 Boylan "Easy Mount" Brackets
- 3 Steel or Concrete Barrier



### Case Study

#### Anti-Gawk Prevents Disaster In Australian Highway Rock Fall

Date 18/05/2012

Crash barriers are designed to save lives but a deployment of Steel Barrier and Anti-Gawk on the Nepean Highway at Frankston, Australia, recently safeguarded the public.

A steep retaining wall collapsed, sending tonnes of rock crashing down towards passing traffic on the highway. Thankfully, the Anti-Gawks strong construction managed to contain the rock fall, preventing a potential tragedy. The incident was serious enough for southbound lanes to be closed for 24 hours.

